

A seven screen cleaner that utilizes seven decks. In the top shoe each screen deck uses 3-26" screen sections with a split-scalp or a scalp-scalp -scalp flow with the screens set at a seven (7) degree pitch. In the bottom shoe each screen deck uses 4-26" screen sections with a 4-way split-sift flow with the screens set at a 9 degree pitch. A total of 243.75 Square feet of screen area.

STANDARD FEATURES:

- 4" square tubing frame that is 1/4" (6.35mm) thick.
- Exclusive electronic variable speed 1/2" throw on eccentric drive of cleaning shoes for smooth seed flow and maximum seed separation.
- Reverse incline back fan unit to develop up to 11,000 CFM @ 5" SP. Drive setup can easily be changed to match air and electrical requirements.
- Electronic variable speed vibratory inlet feed hopper with adjustable internal gate for uniform seed flow thru air column and onto screens.
- New style heavy duty screen cleaning ball trays so that screens can be changed without removing ball trays.
- 2 calibrated air gate controls that work in combination with back adjustable doors for precise air separation settings.
- Replaceable metal screenways and rubber screen seals for ease of future repair.
- New style shoe hangers and drive connectors for smooth counterbalanced operation.
- Air lock discharge trash augers with bottom access door for ease of cleanout.

CAPACITIES:

Large Seed & Wheat	1,000 - 1,500 Bu./Hr (27 - 40.5 MT/H)
Market Cleaning	2000 - 2500 Bu./Hr. (54 - 67.5 MT/H)

Note: *Capacities may vary depending on seed condition, moisture content, seed varieties, types and volumes of contaminants to be separated and the percentage of foreign material acceptable in the final product.



OPTIONS:

- Over 150 different standard screen sizes available with additional screen sizes available upon request.
- Bottom blast fan for specialized or extreme air separation requirements.
- Grease line package to grease machine from central location.
- Various motor drive packages of 50 or 60 Hertz, Single or Three phase, TEFC or Ex-Proof
- Side mounted control panel to control electronic variable speeds from one location.
- Calibrated hopper gate control extended down to side of machine.
- Clean seed conveyors from 10 to 15 feet to convey seed away from cleaner

ELECTRICAL REQUIREMENTS:

Main Fan Motor	15 H.P, 3 Phase, AC
Eccentric Motor	5 H.P, 3 Phase, AC
Vibratory Feeder Motor	1/2 H.P, AC or DC

AIR OUTPUT:

Integral Centrifugal Fan delivering up to 8,400 CFM @ 8" S.P



Extreme Height	138 inches / 351 cm
Height with Bottom Fan	155 inches / 394 cm
Extreme Width	89 inches / 226 cm

Extreme Length	189 inches / 480 cm
Width on Floor	72 inches / 183 cm
Length on Floor	189 inches / 480 cm

FLOW PATTERN:

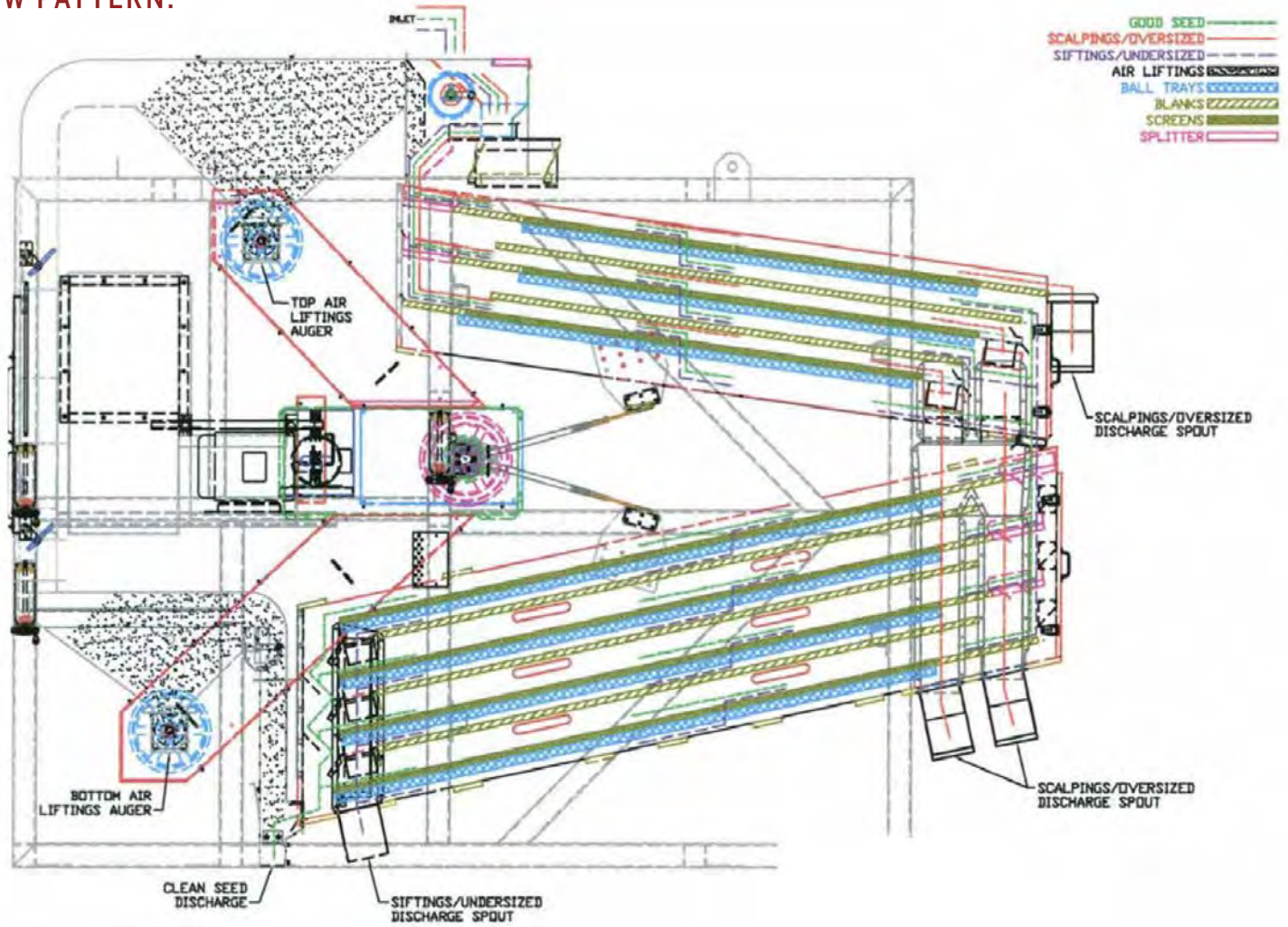

SIDE VIEW

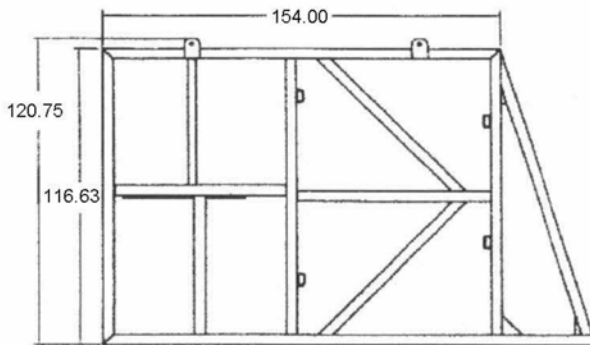

FRONT VIEW

