

RAD's high-efficiency HAMMER Mills are made of 56 RHC carbon steel.

These mills are capable of handling 1.5 to 21.5 tons/hr.

- Heavy-duty, high-quality assembly
- Hammer rods
- Magnetized drawer to separate metal objects
- 1/16" To 1/2" sifters for different types of grain
- Safety shut-off switch on the door
- Grain homogeneity and profitability ensured
- Loading and unloading system available
- Many accessories available



MODEL MX2000

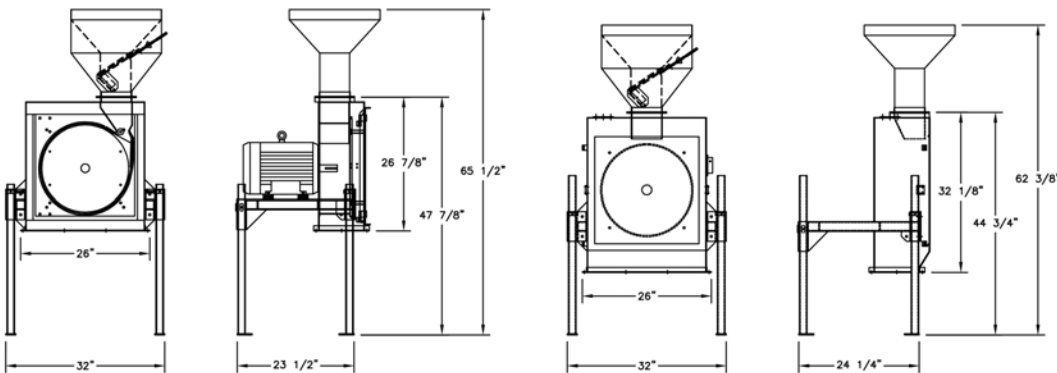

	GRAIN	SCREEN SIZE
Hog	Dry Shelled Corn	1/8", 5/32", 3/16", 1/4"
	Wet Corn	1/4"
	Wheat, Oats, Barley	1/8", 5/32"
Dairy Cattle	Dry Shelled Corn	1/4", 5/16"
	Wet Corn	3/8"
	Wheat, Oats, Barley	5/32"
Poultry	Dry Shelled Corn	3/16", 1/4"
	Wheat, Oats	5/32"

CAPACITY IN TONS/HOUR BASED ON GRAIN AND SCREEN SIZE:

MOTOR	7.5 H.P.			10 H.P.			15 H.P.		
	Corn	Wheat	Barley	Corn	Wheat	Barley	Corn	Wheat	Barley
1/16"	0.5	0.6	0.3	0.7	0.8	0.4	1.0	1.1	0.5
3/32"	0.8	0.9	0.4	1.1	1.2	0.6	1.7	1.9	0.9
1/8"	1.7	1.9	0.9	2.3	2.5	1.2	3.5	3.8	1.8
5/32"	2.1	2.3	1.1	2.8	3.1	1.4	4.2	4.6	2.1
3/16"	2.5		1.2	3.3		1.7	4.9		2.5
7/32"	2.8		1.4	3.7		1.9	5.6		2.8
1/4"	3.1		1.6	4.2		2.1	6.3		3.2
5/16"	3.8		1.9	5.1		2.6	7.7		3.9
3/8"	4.5			6.0			9.0		
1/2"	6.1			8.2			12.3		



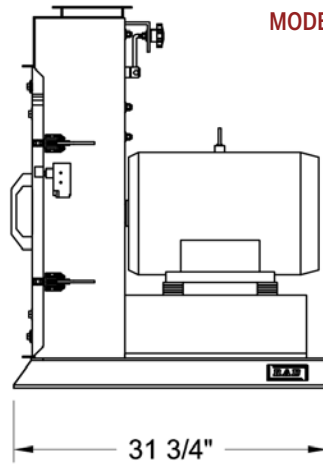
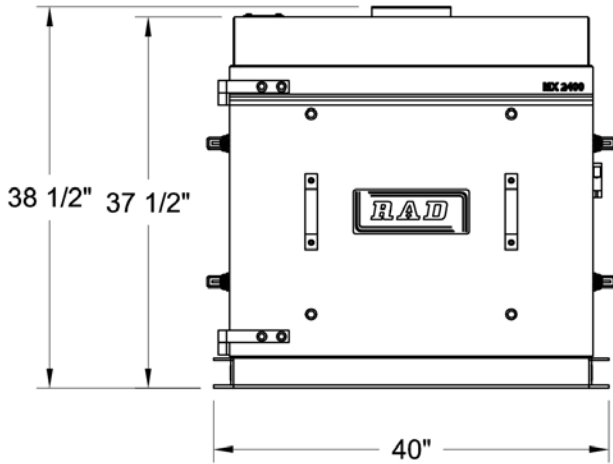

MODEL MX2400



CAPACITY IN TONS/HOUR BASED ON GRAIN AND SCREEN SIZE:

MOTOR	20 H.P.			25 H.P.			30 H.P.			
	SCREEN	Corn	Wheat	Barley	Corn	Wheat	Barley	Corn	Wheat	Barley
1/16"		1.2	1.4	0.7	1.5	1.7	0.8	1.8	1.9	0.9
3/32"		1.9	2.1	1.1	2.6	2.7	1.4	3.0	3.3	1.6
1/8"		4.0	4.4	2.1	5.0	5.6	2.7	6.0	6.7	3.2
5/32"		4.9	5.4	2.5	6.2	6.7	2.9	7.4	8.0	3.7
3/16"		5.8		3.0	7.4		3.7	9.0		4.4
7/32"		6.5		3.3	8.2		4.1	9.8		4.9
1/4"		7.4		3.7	9.2		4.7	11.0		5.6
5/16"		8.9		4.6	11.2		5.7	13.5		6.8
3/8"		10.5			13.1			15.7		
1/2"		14.4			18.0			21.5		

SCREEN SIZE CHART

	GRAIN	SCREEN SIZE
Hog	Dry Shelled Corn	1/8", 5/32", 3/16", 1/4"
	Wet Corn	1/4"
	Wheat, Oats, Barley	1/8", 5/32"
Dairy Cattle	Dry Shelled Corn	1/4", 5/16"
	Wet Corn	3/8"
	Wheat, Oats, Barley	5/32"
Poultry	Dry Shelled Corn	3/16", 1/4"
	Wheat, Oats	5/32"

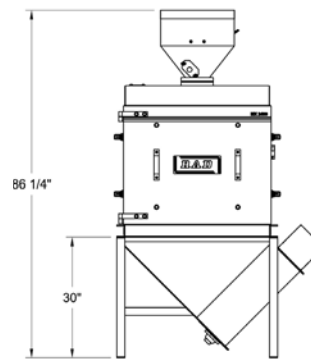

45° UNLOADING HOPPER FOR 6" Ø OR 8" Ø AUGER

Dimensions and specifications are subject to change without notice.

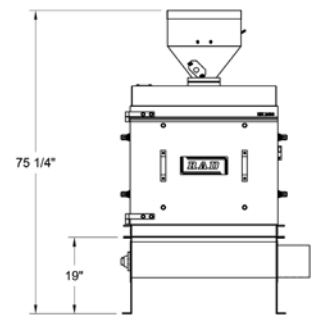

HORIZONTAL UNLOADING HOPPER FOR 6" Ø OR 8" Ø AUGER

