

# Portable Bag Sewer NP-7

## SINGLE THREAD CHAIN STITCH

**IDEAL FOR CLOSING BAGS  
FOR AGRICULTURAL  
PRODUCTS, ANIMAL FEEDS,  
FERTILIZER, FLOUR,  
CHEMICALS, ETC.**

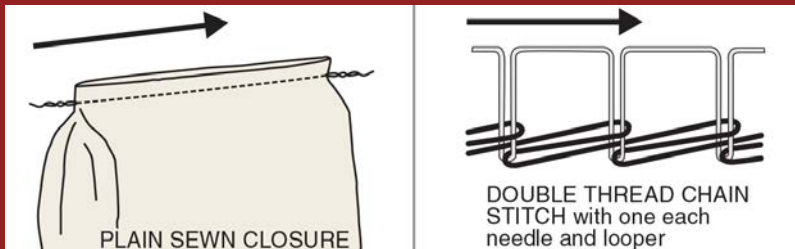

**The NP-7A** has a robust construction for reliable operation with minimal maintenance. Specially designed features extend the life of the equipment; plastic shock resistant isolation handle, automatic oiling system for

lubrication of moving components, extra wide feed dogs, automatic thread cutting and our improved steel cam.

An overhead, suspended, spring balancer support and tape attachments are also available at an additional cost.

### STANDARD FEATURES & SPECIFICATIONS:

- For kraft paper, cotton, hessian, jute, PP/PE woven cloth and other bag materials.
- High-speed revolution: 1,700 - 1,900 rpm (+/-200 r.p.m)
- 8.5 mm (fixed) /3 stitches per inch
- Safety plastic handle for insulation
- Automatic thread cutter
- Uses needle: DNx1 #25
- Oil pump lubrication. Uses Tellus #32 oil.
- Steel cam (no plastic parts)
- Minimum maintenance
- Weight: 6kg(13 lbs.) with thread
- Drive motor: 65~70W 50/60Hz,1-ph. 12V, 24V, 110V, 220V or 240V

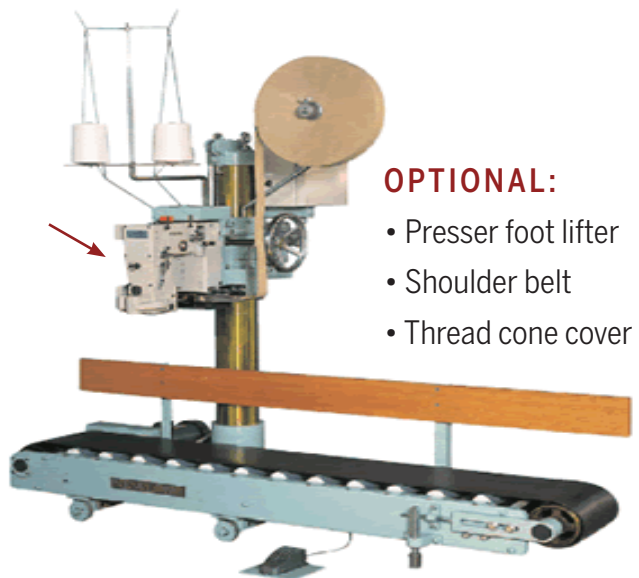

### OPTIONAL:

- Presser foot lifter
- Shoulder belt
- Thread cone cover